

CAVEX[®]hygienic

Stainless steel gearboxes

CAVEX[®]

German Drive Technology



CAVEX[®]HD

www.CAVEX-GmbH.com

Product overview and applications:

CAVEX®



Applications:

- **Developed for the food industry and chemical/pharmaceutical applications**
- **Full stainless steel casing**
- **CAVEX® original gearing system**

CAVEX® unit implements all the requirements of a “hygienic design” and combines them with the CAVEX® product properties that provide a high load capacity, the possibility of high ratios in space saving surroundings and low noise emission. Worldwide CAVEX® now offers the first worm gearbox which has been exclusively developed for the food and beverage and the chemical and pharmaceutical industries.

An optimal cleaning is ensured through the use of stainless steel and a gearbox casing design that is characterized by ‘rounded’ outer surfaces. There are multiple uses: Firstly, the new hygienic gearboxes can replace conventional solutions that, up to now, had to be sealed off from critical zones behind complex stainless steel covers, and secondly, surface coated gearboxes can be replaced, as they had always been a compromise. The HD-S gearbox is available in the sizes 40 and 63. Furthermore, our customers benefit from worldwide availability and our comprehensive CAVEX® service network.

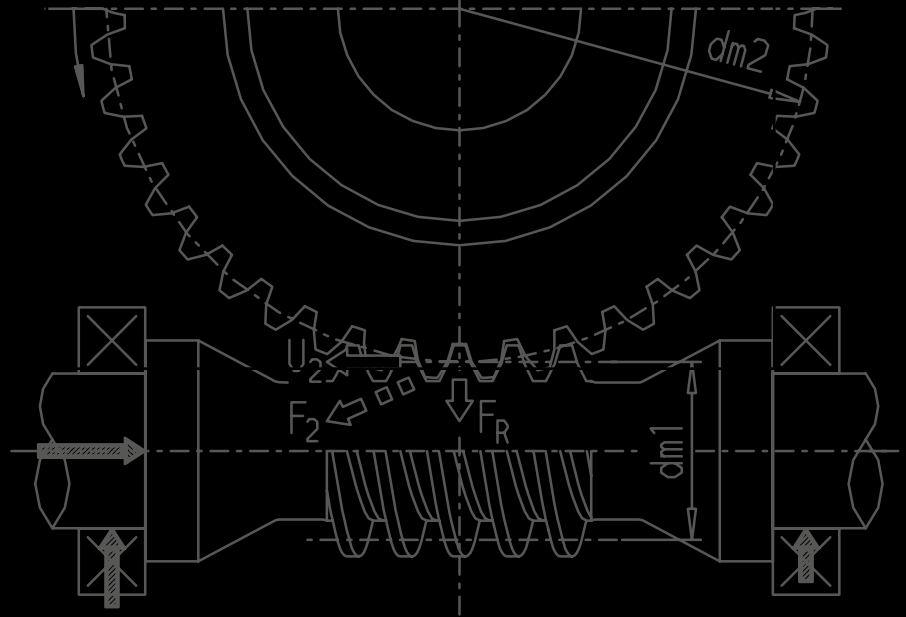

German Drive Technology

Product overview CAVEX®HD-S gearboxes

The CAVEX®HD-S gearboxes are available in 2 different sizes. They can be adapted to different motors.

Key components of CAVEX®HD-S gearboxes and their main features:

Description	Main Feature
Housing	Material stainless steel 1.4404
Input shaft	Material steel, with CAVEX® gearing
Output shaft	Material stainless steel 1.4404
Worm wheel rim	Material bronze, with CAVEX® gearing
Input shaft seal	Standard VITON, NBR
Output shaft seal	Standard VITON, NBR
Input shaft bearing	Angular contact ball bearings
Output shaft bearing	Grooved ball bearing
Lubricant	Oil or grease with H1 approval

Technical data CAVEX®HD-S gearboxes

HD-S 40 with 0,25 kW motor

Ratio (n_1/n_2)	4,83	7	8,25	10,33	13,50	16	19,50	23	29	39	49	61	70
n_1 [1/min]	1500	1500	1500	1500	1500	1500	1500	1500	1500	1500	1500	1500	1500
T_{1N} [Nm]	1,6	1,6	1,6	1,6	1,6	1,6	1,6	1,6	1,6	1,6	1,6	1,6	1,6
T_{2N} [Nm]	7	11	12	15	19	23	27	31	37	48	57	60	60
Gear efficiency [%]	95	94	93	92	90	88	87	85	80	77	73	70	68
T_{2max} [Nm]	60	60	60	60	60	60	60	60	60	60	60	60	60

HD-S 40 with 0,37 kW motor

Ratio (n_1/n_2)	4,83	7	8,25	10,33	13,50	16	19,50	23	29	39	49	61	70
n_1 [1/min]	1500	1500	1500	1500	1500	1500	1500	1500	1500	1500	1500	1500	1500
T_{1N} [Nm]	2,4	2,4	2,4	2,4	2,4	2,4	2,4	2,4	2,4	2,4	2,4	2,4	2,4
T_{2N} [Nm]	11	16	18	23	29	34	41	47	56	60	60	60	60
Gear efficiency [%]	95	94	93	92	90	88	87	85	80	77	73	70	68
T_{2max} [Nm]	60	60	60	60	60	60	60	60	60	60	60	60	60

HD-S 63 with 0,55 kW motor

Ratio (n_1/n_2)	5,17	6,60	8,25	10,33	12,67	15,50	19,50	24,50	31	39	49	61	70
n_1 [1/min]	1500	1500	1500	1500	1500	1500	1500	1500	1500	1500	1500	1500	1500
T_{1N} [Nm]	3,5	3,5	3,5	3,5	3,5	3,5	3,5	3,5	3,5	3,5	3,5	3,5	3,5
T_{2N} [Nm]	17	22	27	33	40	48	59	73	87	105	125	149	167
Gear efficiency [%]	95	94	93	92	90	88	87	85	80	77	73	70	68
T_{2max} [Nm]	200	200	200	200	200	200	200	200	200	200	200	200	200

HD-S 63 with 0,75 kW motor

Ratio (n_1/n_2)	5,17	6,60	8,25	10,33	12,67	15,50	19,50	24,50	31	39	49	61	70
n_1 [1/min]	1500	1500	1500	1500	1500	1500	1500	1500	1500	1500	1500	1500	1500
T_{1N} [Nm]	4,8	4,8	4,8	4,8	4,8	4,8	4,8	4,8	4,8	4,8	4,8	4,8	4,8
T_{2N} [Nm]	24	30	37	46	55	65	81	100	119	144	172	200	200
Gear efficiency [%]	95	94	93	92	90	88	87	85	80	77	73	70	68
T_{2max} [Nm]	200	200	200	200	200	200	200	200	200	200	200	200	200

HD-S 63 with 1,1 kW motor

Ratio (n_1/n_2)	5,17	6,60	8,25	10,33	12,67	15,50	19,50	24,50	31	39	49	61	70
n_1 [1/min]	1500	1500	1500	1500	1500	1500	1500	1500	1500	1500	1500	1500	1500
T_{1N} [Nm]	7	7	7	7	7	7	7	7	7	7	7	7	7
T_{2N} [Nm]	34	43	54	67	80	95	119	146	174	200	200	200	200
Gear efficiency [%]	95	94	93	92	90	88	87	85	80	77	73	70	68
T_{2max} [Nm]	200	200	200	200	200	200	200	200	200	200	200	200	200

Basic parameters:

- 50 Hz
- S1 operation
- Ambient temperature = 20°C
- Oil type ISO VG 460 (with H1 approval)
- Operating hours approx. 10.000 h

Mounting positions

The following mounting positions are possible (schematic diagram with CAVEX®HD-S gearboxes)

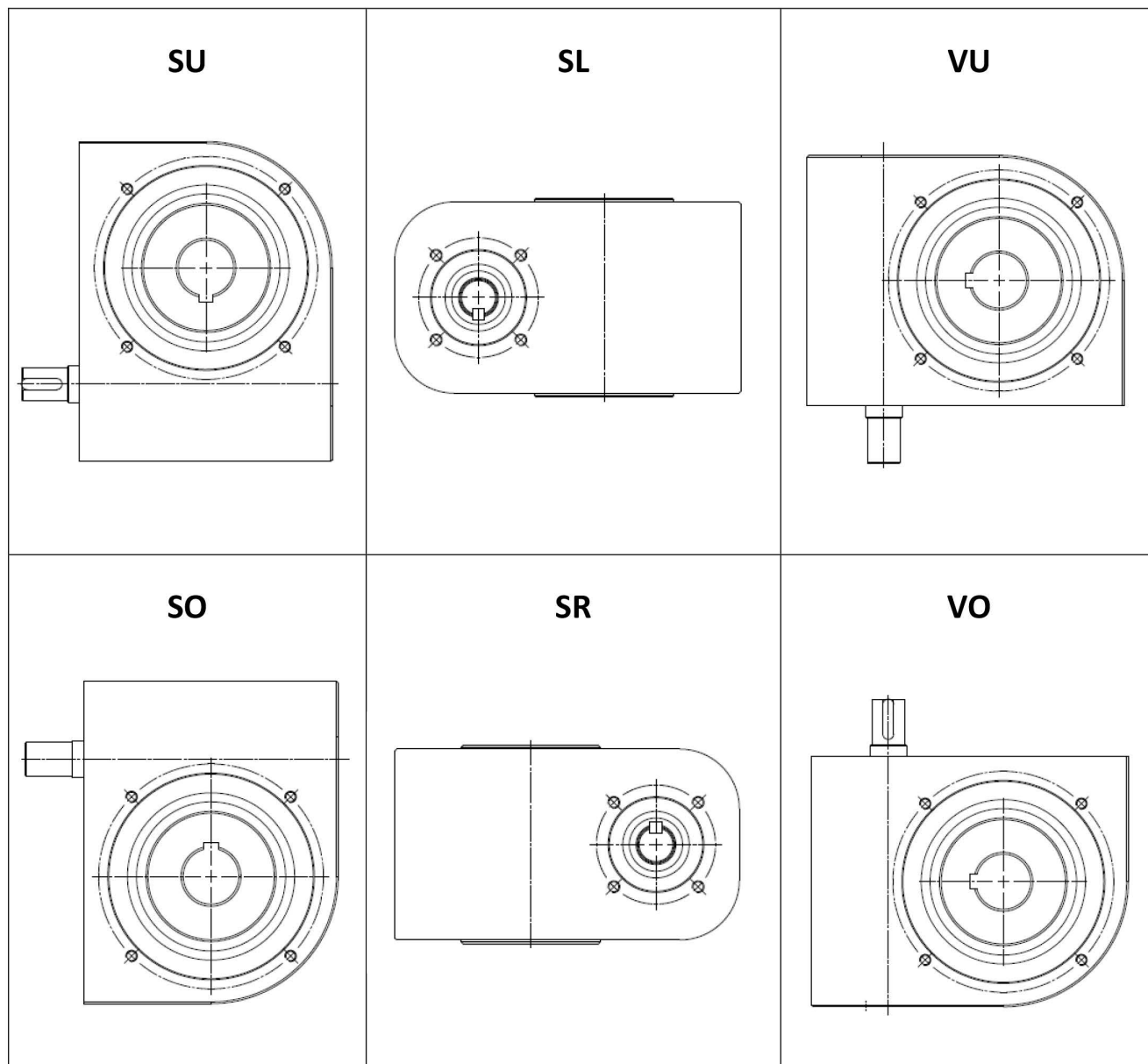

SU: Worm below, **SL:** Worm on left, **VU:** Worm vertically below,
SO: Worm above, **SR:** Worm on right, **VO:** Worm vertically above

Dimensional drawings

Dimensions of the CAVEX®HD-S gearboxes

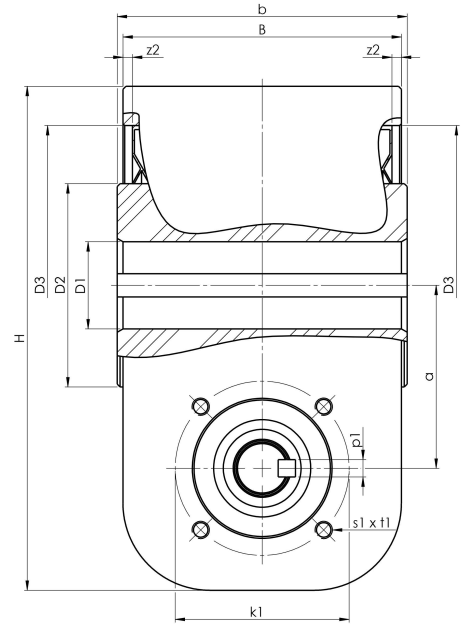
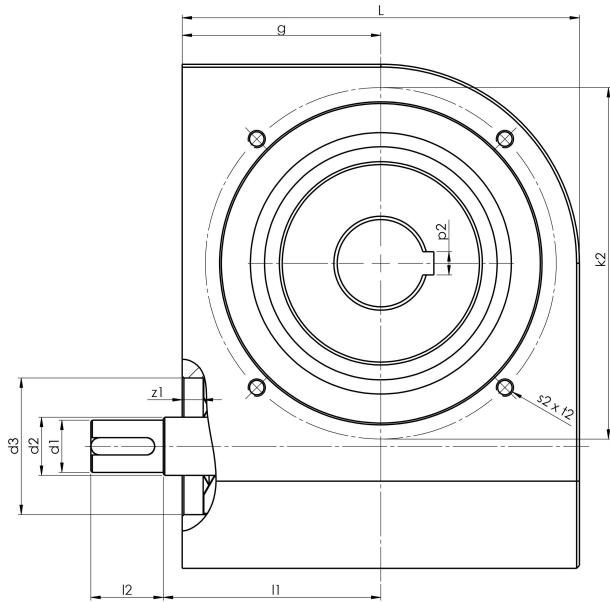

Size	a	b	B	d1	d2	d3	D1	D2	D3	g	H	k1	k2	l1	l2	L	p1	p2	s1 x t1	s2 x t2	z1	z2
40	40	79	75	10 m6	12 h7	32 H7	20 H7	40 h9	68 H7	58,5	133,5	43	79	54	11	96	3 JS9	6 JS9	M6 x 10	M6 x 10	3	3
63	63	100	96	18 m6	20 h7	47 H7	30 H7	70 h9	110 H7	75	189,4	60	121	75	25	137	6 JS9	8 JS9	M6 x 10	M6 x 10	7	3

Appendix

Request form CAVEX®hygienic

Query:	Author:	Date:
Customer:	Contact person:	Place:

Request	Example	Unit	
Application	Freeze dryer / pharmaceutical industry		
Type of gearbox	worm, helical, coaxial, ...		
Nominal power (installed electrical power)		[W]	
Nominal output torque		[Nm]	
Nominal input speed		[min ⁻¹]	
Ratio			
Desired service life		[h]	
Operating mode (Zyklus/ ED)			
Ambient temperatures		[°C]	
Contamination in ambient air	vapours, ...		
Max. space available		H x W x D [mm]	
Annual quantity		piece	
Batch		piece	
Target price		€	

Your notes, remarks, additional information:

We look forward to your visit!

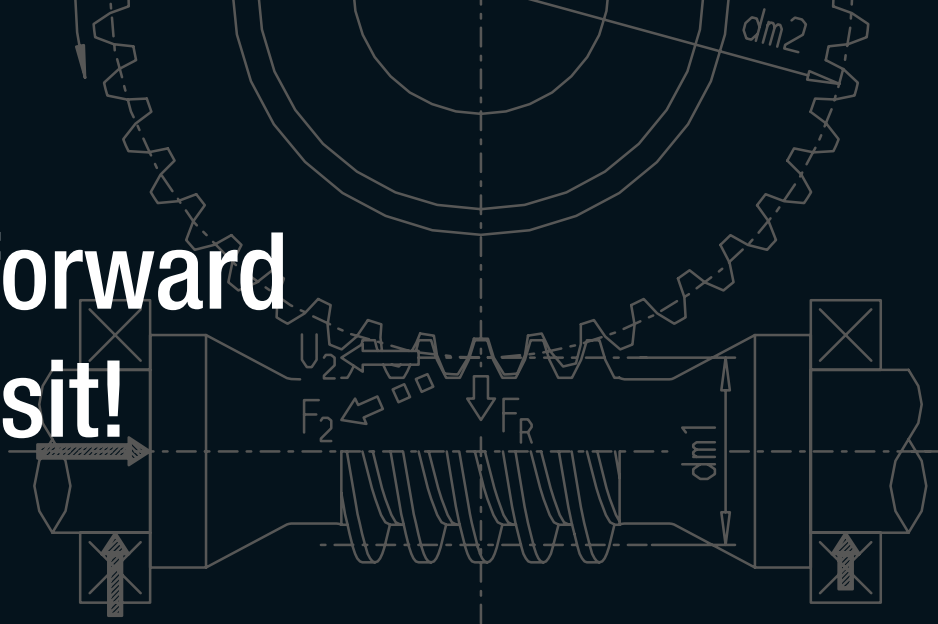

CAVEX®

German Drive Technology



CAVEX® GmbH & Co. KG

Tübinger Straße 2

D-72131 Offerdingen

Tel.: +49 (0) 74 73 95 546 - 0

Fax: +49 (0) 74 73 95 546 - 88

www.CAVEX-GmbH.com